

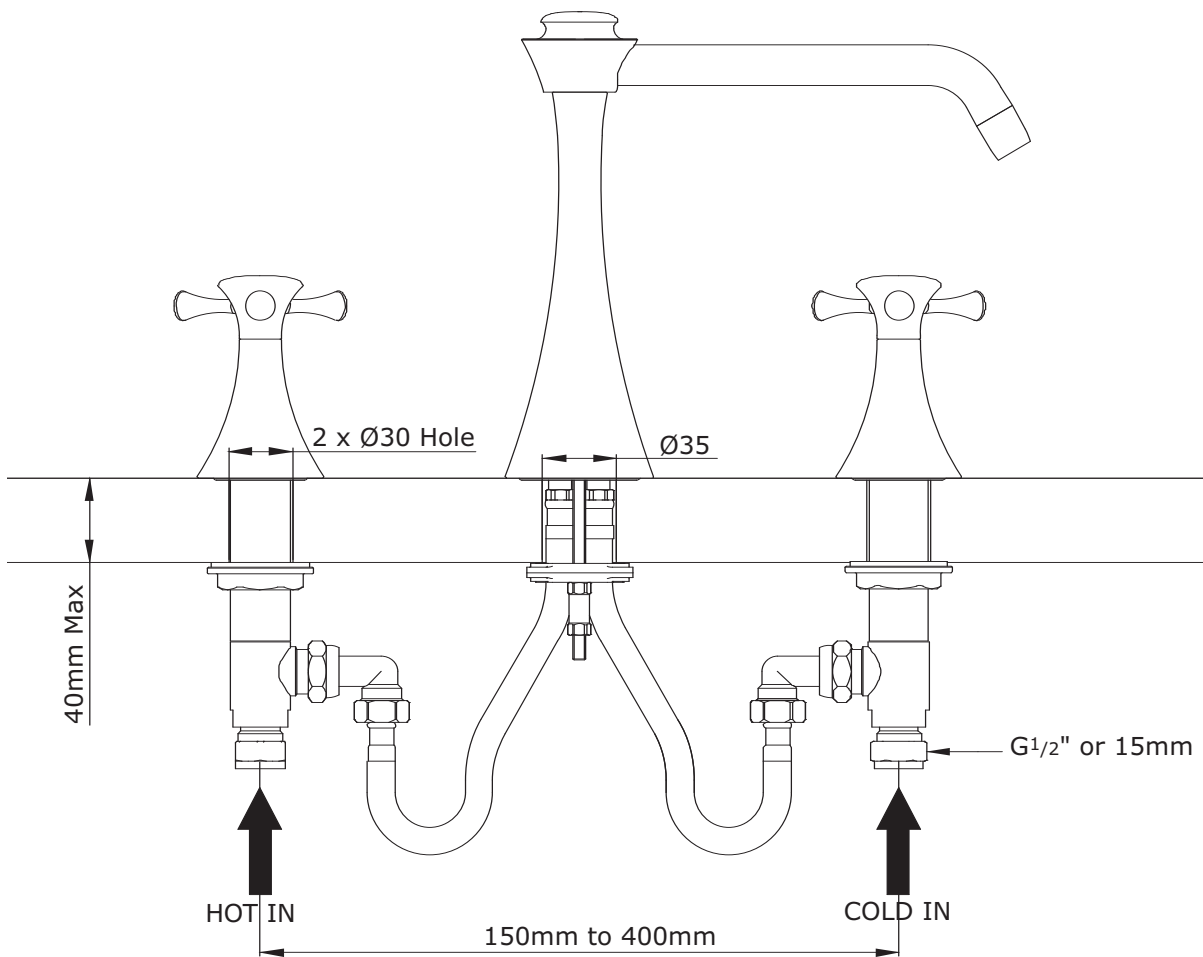

Specification Sheet - N.4592 - Oasis by Mark Wilkinson

Specifications



- Premium quality tapware
- Made in England, designed by Mark Wilkinson for Perrin & Rowe
- Produced from solid brass
- German quarter-turn ceramic disc valves. Min 5°C - max 85°C
- Suitable for low and uneven water pressure. Max inlet pressure 500 kpa
- Select from Chrome, Nickel, Pewter, Gold, English Bronze or uncoated bare brass
- Five year warranty

